



TI-P006-01  
 CH Issue 13

## DP143, DP143G, DP143H and DP143Y Pilot Operated

# Pressure Reducing Valves with Cast Steel Bodies

### Description

The DP143, DP143G, DP143H and DP143Y pilot operated pressure reducing valves have been manufactured using cast steel.

Available types	<b>DP143</b>	Suitable for steam applications
	<b>DP143G</b>	Is a soft seal version available for compressed air and inert industrial gases. <b>Note: It is not recommended for oxygen service.</b>
	<b>DP143H</b>	Is a high temperature version for use up to 350 °C.
	<b>DP143Y</b>	Having a lower rate pressure control spring, making it suitable for steriliser/autoclave applications

### Sizes and pipe connections

DN15LC - Low Capacity version, DN15, DN20, DN25, DN32, DN40, DN50 and DN80.

Standard flanges: EN 1092 PN40, BS 10 Table 'J' and ANSI 300.

Available on request: ANSI 150 and JIS 20.

### K<sub>v</sub> values

The K<sub>v</sub> maximum values shown below are **full** capacities and should be used for safety valve sizing purposes only.

DN15LC	DN15	DN20	DN25	DN32	DN40	DN50	DN80
1.0	2.8	5.5	8.1	12.0	17.0	28.0	64.0

For conversion:

$$C_v \text{ (UK)} = K_v \times 0.963$$

$$C_v \text{ (US)} = K_v \times 1.156$$

**Note:** Where the internal balance pipe is used the valve capacity will be reduced.

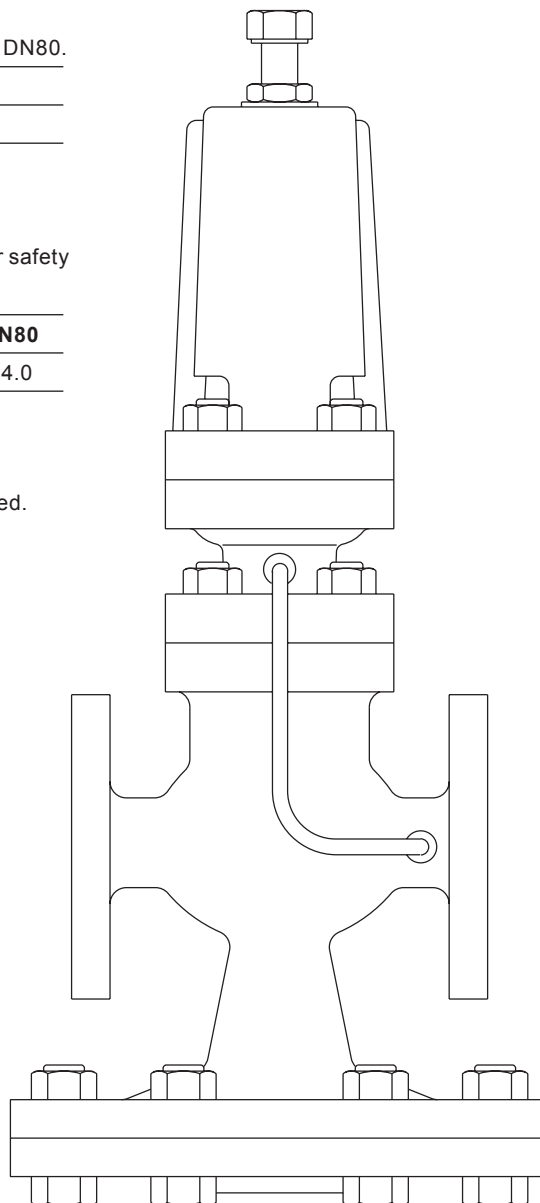

## Pressure / temperature limits

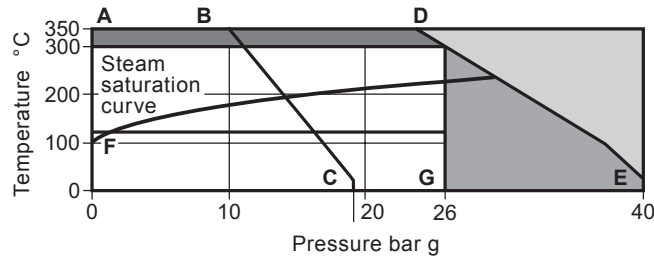

The product **must not** be used in this region.

Due to the material strength of the main diaphragm chamber the product **must not** be used in this region.

Use the high temperature DP143H version in this region.

**A-D-E** Flanged EN 1092, PN40, ANSI 300 and BS 10 Table J.

**A-B-C** Flanged ANSI 150.

**F-G** DP143G limited to 120 °C @ 26 bar g.

**Note:** Two colour coded pressure adjustment springs are available for the following downstream pressure ranges:

**Red** 0.2 bar g to 17 bar g

**Grey** 16.0 bar g to 24 bar g

**Yellow** 0.2 to 3.0 bar g (DP143Y only)

Body design conditions		PN40
Maximum design pressure	<b>A-B-C</b>	18.9 bar g @ 20 °C
	<b>A-D-E</b>	Limited to 26 bar g
Maximum design temperature		350 °C @ 24 bar g
Minimum design temperature		0 °C
Maximum upstream pressure for saturated steam service	<b>A-D-E</b>	26 bar g
	<b>A-B-C</b>	14 bar g
Maximum operating temperature	<b>DP143</b>	300 °C @ 26 bar g
	<b>DP143G</b>	120 °C @ 26 bar g
	<b>DP143H</b>	350 °C @ 24 bar g
Minimum operating temperature		0 °C
<b>Note:</b> For lower operating temperatures consult Spirax Sarco		
Maximum differential pressure	<b>A-D-E</b>	26 bar
	<b>A-B-C</b>	14 bar
Designed for a maximum cold hydraulic test pressure of:		60 bar g
<b>Note:</b> With internals fitted, test pressure must not exceed:		40 bar g

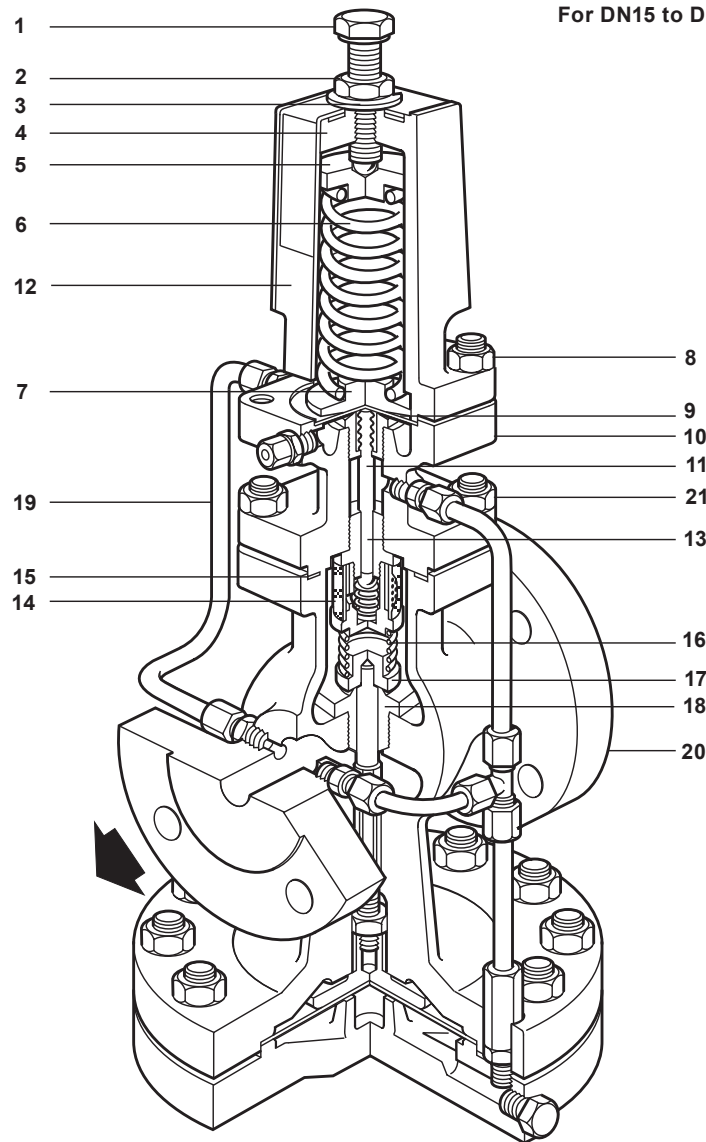

**Materials**

No. Part	Material		
1	Adjustment screw	Steel	BS 3692 Gr. 8.8
2	Adjustment lock-nut	Steel	BS 3692 Gr. 8
3	Washer	Stainless steel	BS 1449 304 S16
4	Spring housing	Cast steel	DIN 17245 GS C25
5	Top spring plate	Stainless steel	BS 970 220 Mo7
6	Pressure adjustment spring	Stainless steel	BS 2056 302 S25
7	Bottom spring plate	Steel	BS 970 220 Mo7
8	Spring housing	Securing nuts	Steel BS 3692 Gr. 8
		Securing studs	Steel BS 4439 Gr. 8.8 DN15 to DN80 M10 x 30 mm
9	Pilot diaphragm	Stainless steel	BS 1449 316 S31
10	Pilot valve housing	Steel	
		DN15 to DN50	DIN 17245 GS C25
		DN80	GP 240 GH+N
11	Pilot valve plunger	Stainless steel	BS 970 431 S29
12	Spring housing cover	Stainless steel	BS 1449 304 S12

No. Part	Material		
13	Pilot valve and seat unit	Stainless steel	BS 970 431 S29 DP143G is stainless steel/nitrile
14	Internal strainer	Stainless steel	BS 1449 304 S16
15	Body gasket	Stainless steel reinforced exfoliated graphite	
16	Main valve return spring	Stainless steel	BS 2056 302 S16
17	Main valve	Stainless steel	BS 970 431 S29 DP143G is stainless steel/nitrile
18	Main valve seat	Stainless steel	BS 970 431 S29 DP143G is stainless steel/nitrile
19	Balance pipe assembly	Stainless steel	BS 3605 304 S14
20	Main valve body	Cast steel	DIN 172 45 GS C25
21	Pilot valve housing	Securing nuts	Steel BS 3692 Gr. 8
		Securing studs	Steel BS 4439 Gr. 8.8 DN15 and DN20 M10 x 25 mm DN25 to DN50 M12 x 30 mm DN80 M12 x 40 mm

**DN15 to DN50**

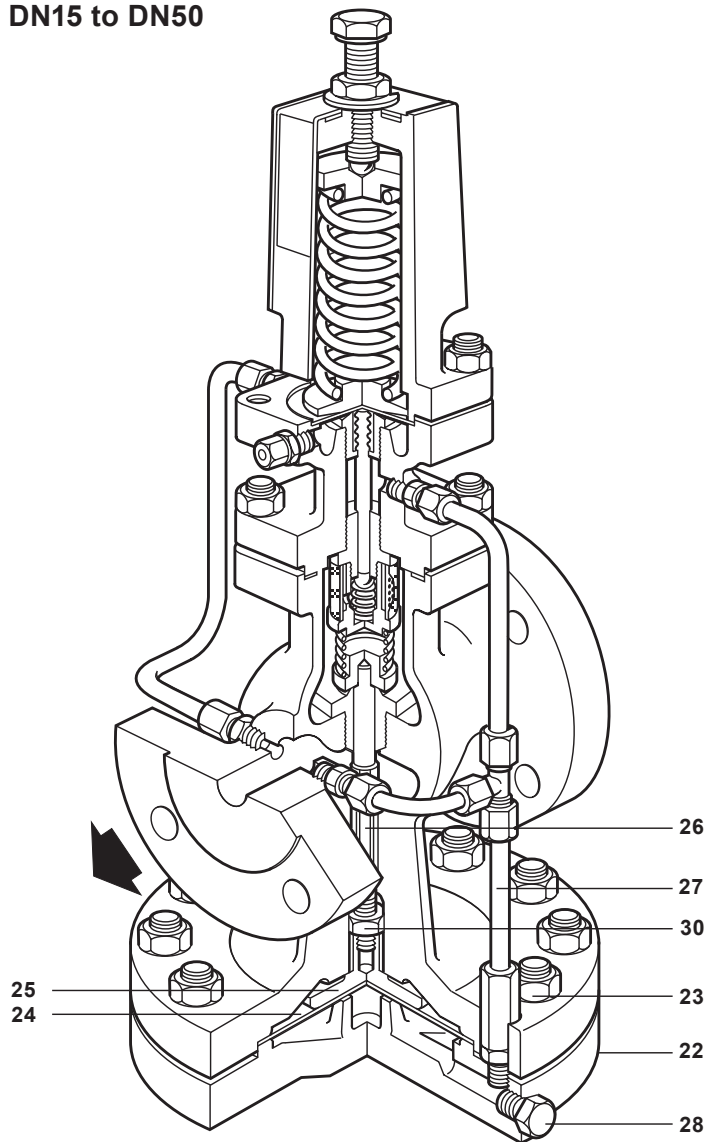

**DN80**

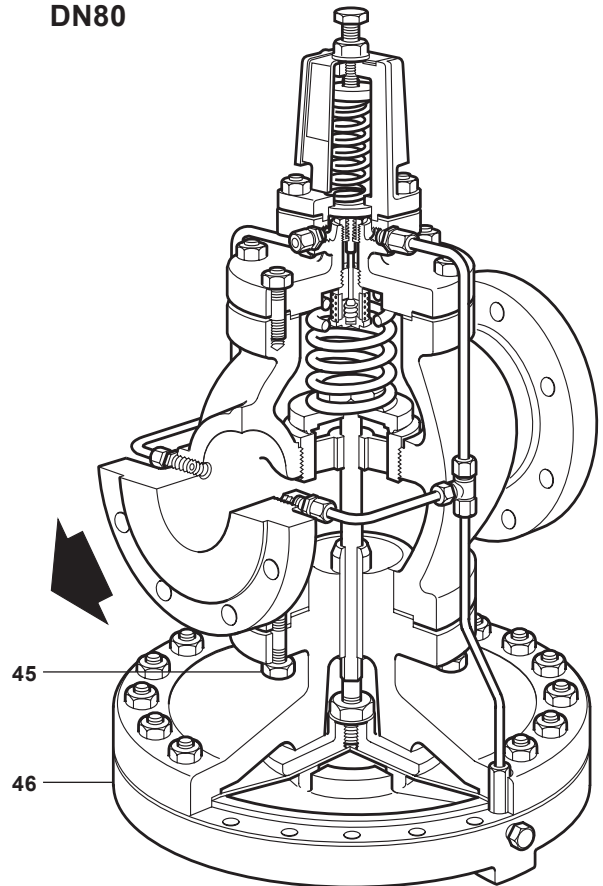

**Materials**

No. Part	Material	
22 Main diaphragm chamber	Cast steel	DIN 17245 GS C25
Securing nuts	Steel	BS 3692 Gr. 8
	Steel	BS 3692 Gr. 8.8
23 Main diaphragm	Securing bolts	DN15 and DN20 M12 x 50 mm
		DN25 and DN32 M12 x 60 mm
		DN40 and DN50 M12 x 65 mm
		DN80 M12 x 80 mm
24 Main diaphragms	Stainless steel	BS 1449 316 S31
25 Main diaphragm plate	Stainless steel	BS 970 431 S29
26 Push rod	Stainless steel	BS 970 431 S29
27 Control pipe assembly	Stainless steel	BS 3605 304 S14
28 Plug 1/8" BSP	Steel	
29 Pressure pipe union	Steel	
30 Lock-nut	Steel	BS 3692 Gr. 8

No. Part	Material	
Body studs	Steel	BS 4439 Gr. 8.8
	Steel	BS 3692 Gr. 8
45 Body nuts	DN15 to DN80	M12 x 40 mm
	Cast steel	1.0619+N
46 Upper main diaphragm chamber		

For DN15 to DN50, parts 1 to 21, see page 3

**Dimensions / weights (approximate) in mm and kg**

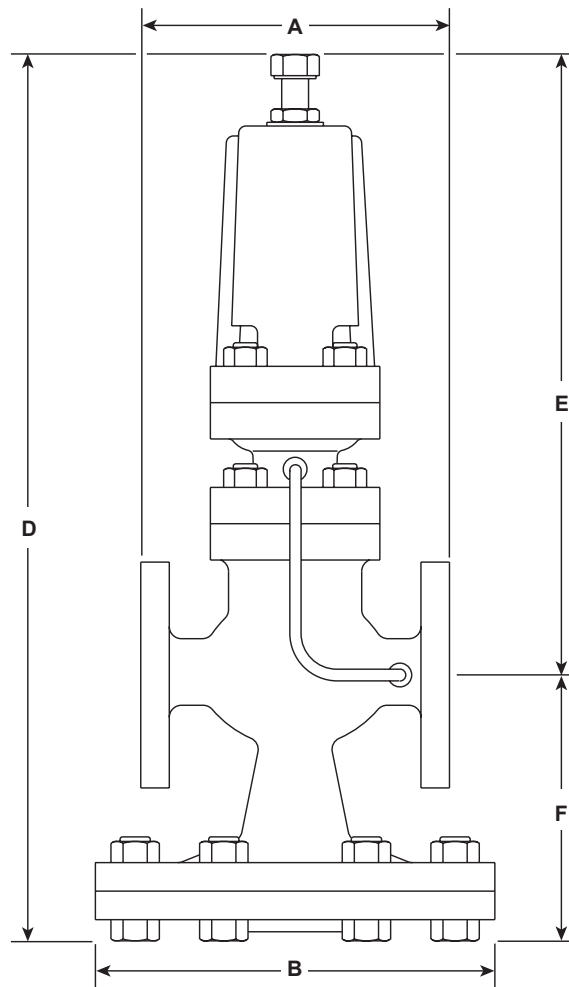

	EN 1092 PN40	ANSI 300	ANSI 150	BS 10 Table J					
Sizes	A	A	A	A	B	D	E	F	Weight
DN15 LC	130	130	122	130	175	405	277	128	15
DN15	130	130	122	130	175	405	277	128	15
DN20	150	150	142	150	175	405	277	128	16
DN25	160	160	156	164	216	440	288	152	23
DN32	180	183	176	184	216	440	288	152	25
DN40	200	209	200	209	280	490	305	185	40
DN50	230	236	230	243	280	490	305	185	42
DN80	310	319	310	325	350	580	322	258	103

## Steam capacities chart

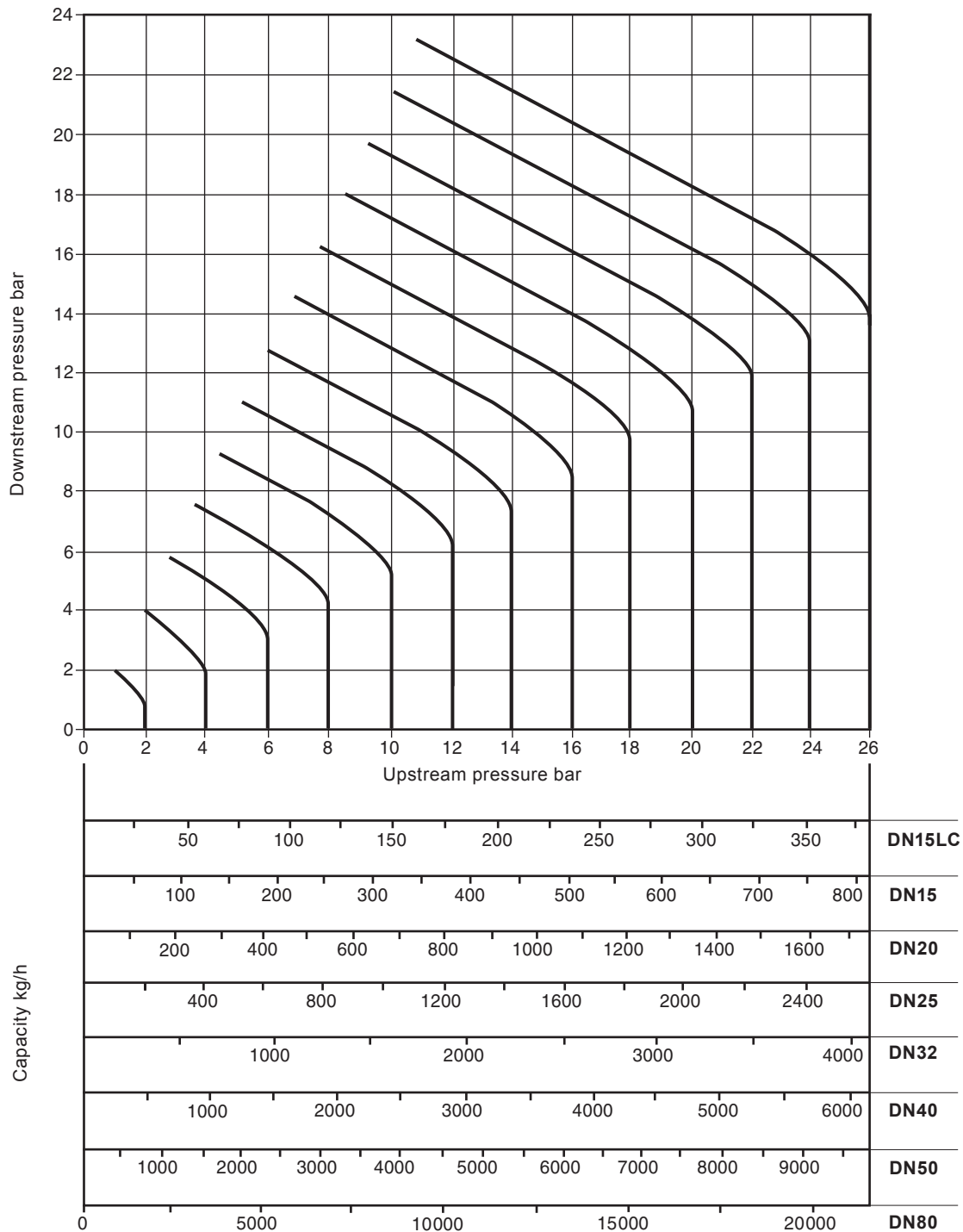

### Note

The capacities quoted above are based on valves fitted with an external pressure sensing pipe. Reliance on the internal balance pipe will mean that capacities may be reduced. In the case of low downstream pressure this reduction could be up to 30% of the valve capacity.

### How to use the chart

#### Saturated steam

A valve is required to pass 600 kg/h reducing from 6 bar to 4 bar. Find the point at which the curved 6 bar upstream pressure line crosses the horizontal 4 bar downstream pressure line. A perpendicular dropped from this point gives the capacities of all DP sizes under these conditions. A DN32 valve, is the smallest size which will carry the required load.

#### Superheated steam

Because of the higher specific volume of superheated steam a correction factor must be applied to the figure obtained from the chart above. For 55 °C of superheat the factor is 0.95 and for 100 °C of superheat the factor is 0.9.

Using the example given for saturated steam, the DN32 valve would pass  $740 \times 0.95 = 703$  kg/h if the steam had 55 °C of superheat. It is still big enough to pass the required load of 600 kg/h.

## Compressed air capacities chart

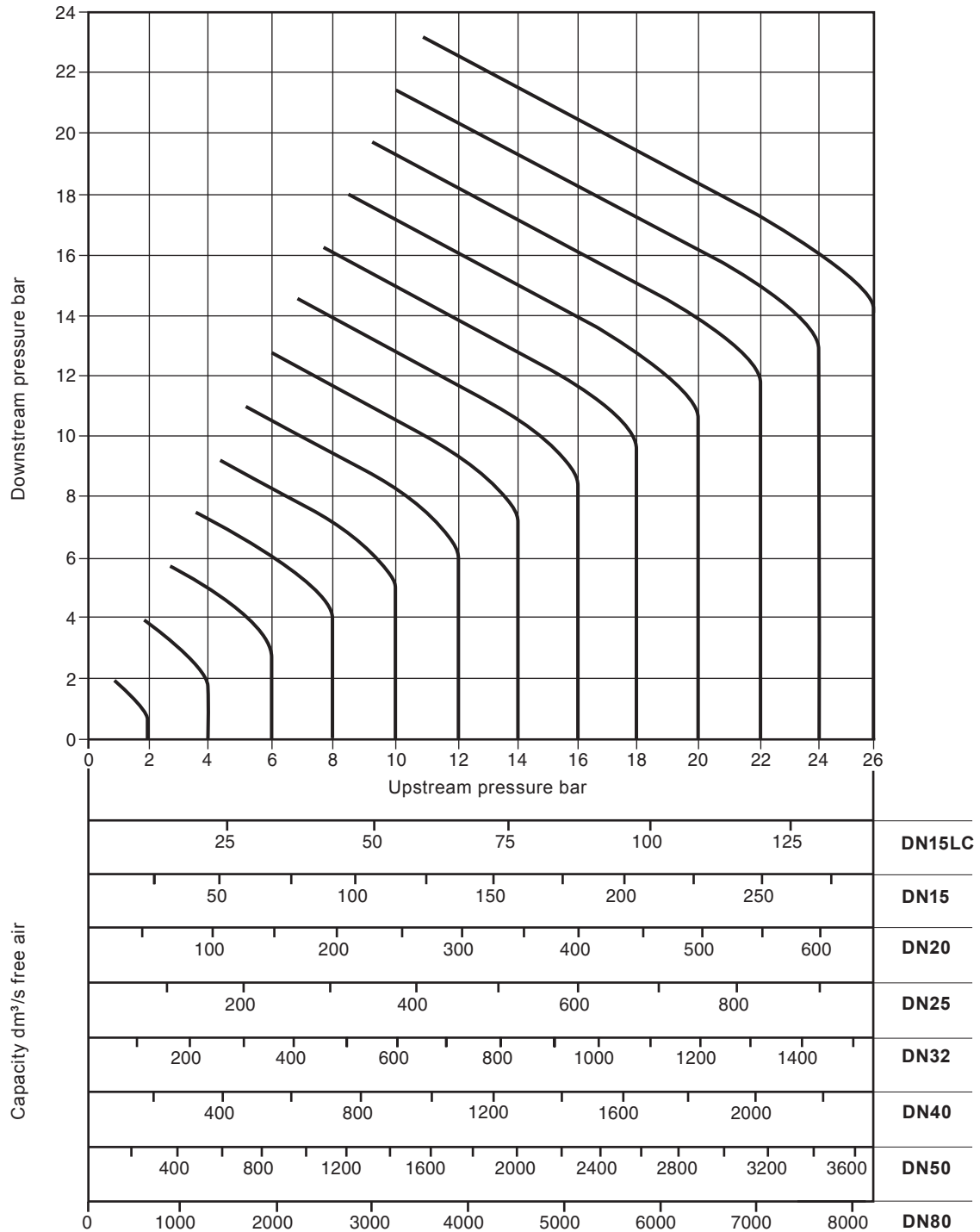

### How to use the chart

Capacities are given in cubic decimetres of free air per second ( $\text{dm}^3/\text{s}$ ). The use of the capacity chart can be best explained by an example. Required, a valve to pass 100  $\text{dm}^3/\text{s}$  of free air reducing from 12 bar to 8 bar.

Find the point at which the curved 12 bar upstream pressure line crosses the horizontal 8 bar downstream pressure line. A perpendicular dropped from this point shows that whereas a DN15LC valve will only pass 57  $\text{dm}^3/\text{s}$  and is therefore not large enough, a DN15 valve will pass approximately 120  $\text{dm}^3/\text{s}$  under these conditions and is the correct valve size to choose.

### Safety information, installation and maintenance

For full details see the Installation and Maintenance Instructions (IM-P006-07) supplied with the product.

#### Installation note:

The valve should be installed in a horizontal pipeline with the direction of flow as indicated by the arrow on the valve body.

### How to order

**Example:** 1 off Spirax Sarco DN32 DP143 pilot operated pressure reducing valve fitted with a red pressure adjustment spring and having flanged EN 1092 PN40 connections.

## Spare parts

### Available spares

Maintenance kit			
A stand-by set of spares for general maintenance purposes and covers all spares marked*			
* Main diaphragm	(2 off)		<b>A</b>
* Pilot diaphragm	(2 off)		<b>B</b>
Pilot valve seal assembly			<b>C</b>
* Pilot valve and plunger assembly			<b>D, E</b>
Main valve assembly			<b>F, H</b>
* Main valve return spring			<b>G</b>
Pressure adjustment spring	<b>Red</b>	DP143, DP143G, DP143H	0.2 to 17 bar
	<b>Grey</b>	DP143, DP143G, DP143H	16 to 24 bar
Control pipe assembly			<b>K</b>
Balance pipe assembly			<b>M, N</b>
* Body gasket	(packet of 3)		<b>O</b>
* Set of spring housing securing studs and nuts	(set of 4)		<b>P</b>
* Set of pilot valve housing securing studs and nuts	(set of 4)		<b>Q</b>
Set of diaphragm chamber securing bolts and nuts	(set of 10)	DN15 and DN20	<b>R</b>
	(set of 12)	DN25 and DN32	
	(set of 16)	DN40 and DN50	
	(set of 20)	DN80	
Set of main body studs and nuts (DN80)	(set of 6)		<b>T</b>
Pushrod and main diaphragm plate assembly			<b>V, W, X</b>

### How to order spares

Always order spares by using the description given in the column headed 'Available spares' and state the size and type of pressure reducing valve.

**Example:** 1 - Main valve assembly for a Spirax Sarco DN15 DP143 pressure reducing valve.

**How to fit.** See the Installation and Maintenance Instructions supplied with the pressure reducing valve. Further copies are available on request.

### Interchangeability of spares

The following table shows how in certain sizes some parts are interchangeable. For example in the line headed 'Main diaphragm' the diaphragm used in the following sizes: DN15LC, DN15 and DN20 is common to these sizes by the letter 'a'. The letter 'b' indicates that sizes DN25 and DN32 use one common diaphragm.

Some parts, particularly pilot and main valve assemblies are specific to particular models e.g. DP143G Interchangeability is therefore restricted to model type for some parts.

† **Please note for storage purposes:** The spare parts marked † are not the same material as those for the DP163, consequently they may not be compatible for interchangeability.

Size	**							
	DN15LC	DN15	DN20	DN25	DN32	DN40	DN50	DN80
Main diaphragm	a	a	a	b	b	c	c	d
Pilot diaphragm	a	a	a	a	a	a	a	a
Pilot valve seal assembly	a	a	a	a	a	a	a	a
Pilot valve and plunger assembly	a	a	a	a	a	a	a	a
Main valve assembly	a	b	c	d	e	f	g	h
Main valve return spring	a	a	a	b	b	c	c	d
Pressure adjustment spring	a	a	a	a	a	a	a	a
† Control pipe assembly	a	a	b	c	d	e	f	g
† Balance pipe assembly	a	a	b	c	d	e	f	g
† Body gasket	a	a	a	b	b	c	c	d
† Set of spring housing securing studs and nuts	a	a	a	a	a	a	a	a
† Set of pilot valve housing securing studs and nuts	a	a	a	b	b	c	c	d
† Set of diaphragm chamber securing bolts and nuts	a	a	a	b	b	c	c	d
† Set of main body studs and nuts	-	-	-	-	-	-	-	a

\*\* Not available for the DP143G



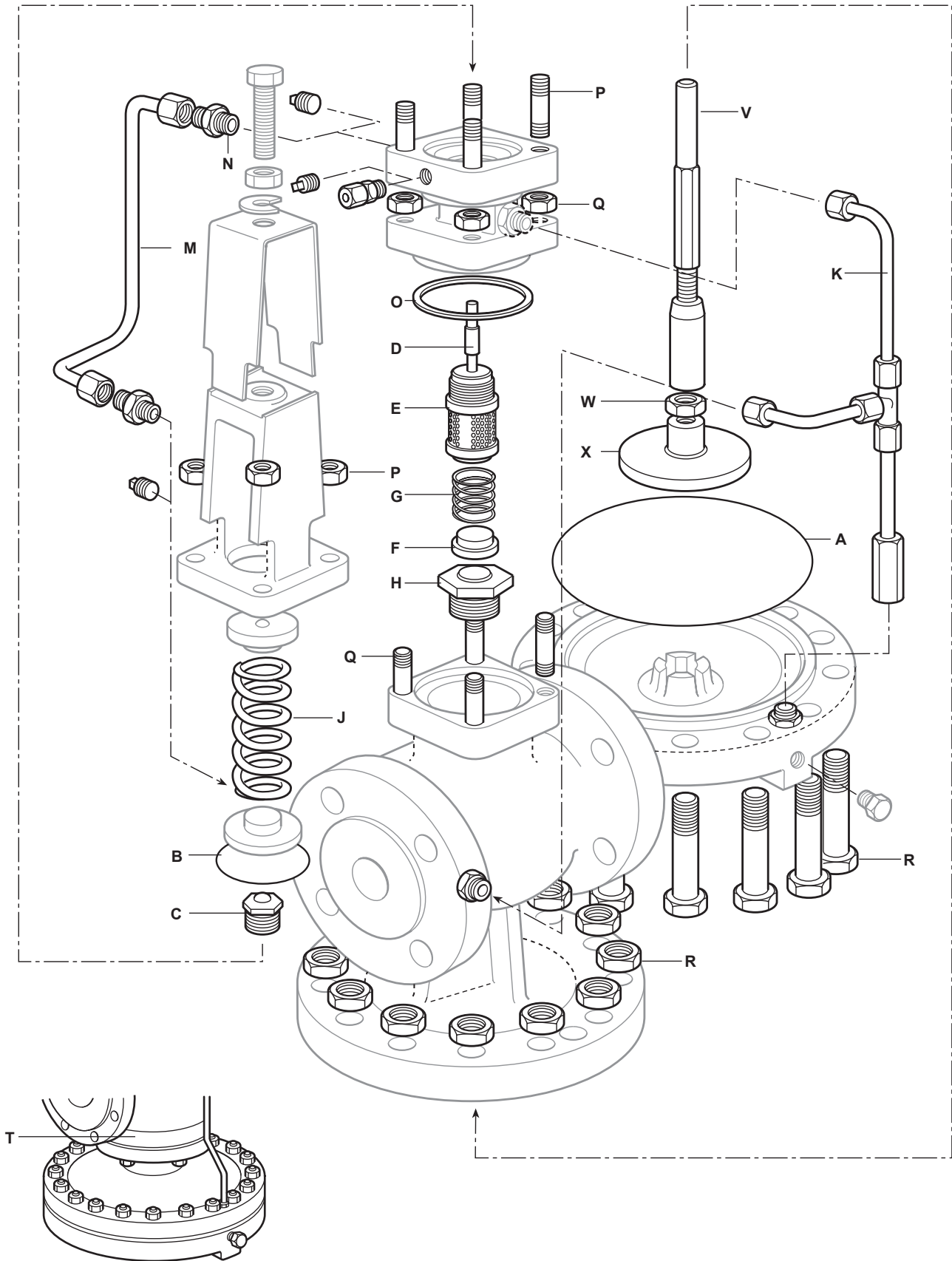

arrangement of main diaphragm chamber DN80 size only.